

Overview

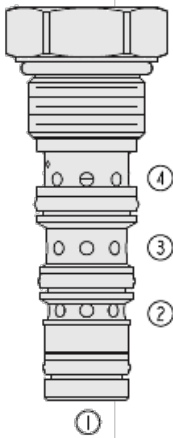

Symbol

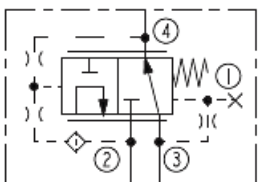

Description

The HTD10-40 is a high pressure, spool type, screw in, cartridge style, hydraulic pressure reducing/relieving valve that maintains the control pressure at the mid-point of the supply and tank pressure.

Operation

The spool is biased to block flow from port 2 to port 3 and allow flow from port 3 to port 4. Pressure applied to port 2 shifts the spool to block flow to port 4 and allow flow from port 2 to port 3 until the pressure at port 3 is at the mid-point of the pressure at port 2 and port 4. The valve relieves flow from port 3 to port 4 if the pressure at port 3 increases above the mid-point. Port 1 is blocked (unused).

Features

- Divides torque between two series motors.
- Accommodates differential flow (size optimized).
- Hardened spool and cage for long life.
- All HyPerformance products are tested to the rigorous standards of the NFPA specification T2.6.1.
- All HyPerformance valves are tested at a verification level of 90% and an assurance of 99%.

Ratings

Pressure Ratings

Pressure rating	350 bar (5075 psi)	- Note: All ports
	420 bar (6090 psi)	- Note: (10% cycle life)
Proof pressure	690 bar (10000 psi)	
Burst pressure	1380 bar (20000 psi)	
Control pressure setting	- Note: Mid-point of supply and tank pressure. Reference performance graph for accuracy	

Flow Ratings

Flow rating	56.8 lpm (15 gpm)	
Maximum pilot flow	1.95 lpm (0.52 gpm)	- Note: Port 2 to 4 (at) 350 bar (5075 psi)

Other Ratings

Cycle life	One million cycles
Corrosion protection	960 hr salt spray per ASTM b117

Temperature Ratings

Operating fluid temperature	-40 to 100 °C (-40 to 212 °F)	- Note: With buna N seals
	-26 to 204 °C (-15 to 400 °F)	- Note: With fluorocarbon seals
	-54 to 107 °C (-65 to 225 °F)	- Note: With urethane seals
Storage temperature	-40 to 70 °C (-40 to 160 °F)	
Ambient temperature	-40 to 90 °C (-40 to 194 °F)	

Operating Parameters

Fluids	Mineral based or synthetic hydraulic fluid with lubricating properties
Fluid viscosity range	7.4 to 420 cSt
Maximum operating contamination level	18/16/13 per ISO 4406

Properties

Unit weight	0.15 kg (0.32 lb)
Internal wetted surface area	141 cm ² (21.8 in ²)

Performance

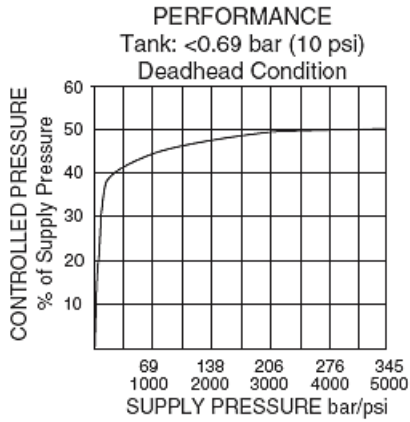

Dimensions

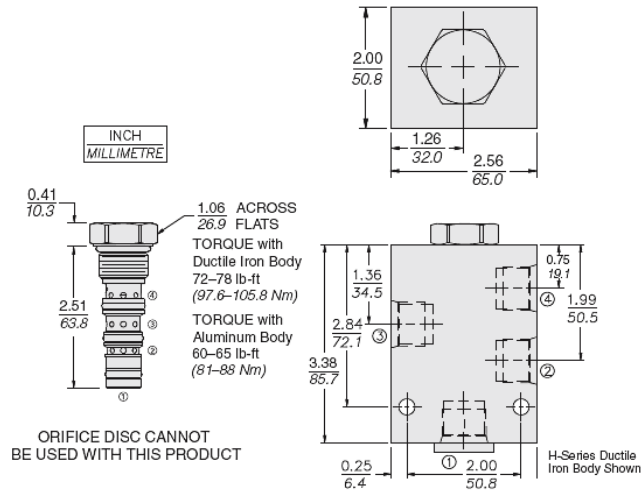

Installation Specifications

Cavity	HVC10-4	
Cartridge installation torque	102 to 115 N-m (75 to 85 ft-lb)	- Note: Steel/ductile iron cavity
	81 to 88 N-m (60 to 65 ft-lb)	- Note: Aluminum cavity
Orientation restriction	None	

Accessories

Seal kit	SK10-4N-MMM	- Note: Buna N
	SK10-4V-MMM	- Note: Fluorocarbon
	SK10-4U-OOO	- Note: Urethane

Order Code

RM316.RU

HTD10-40 -

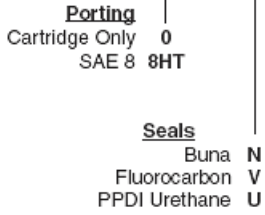

Note: PPDI urethane seals are recommended for operating pressures above 241 bar (3500 psi).

Model Options

HTD10-40-H-J

H Line Body

CODE	DESCRIPTION
0	No Body
8HT	Ductile Iron SAE 8

J Seal

CODE	DESCRIPTION
N	Buna-N
V	Fluorocarbon
U	PPDI Urethane